

Septic tank and aqua privy design

Using water to flush faeces away from a toilet ensures that the waste is separated from the user, helping to control smells and flies. It allows the toilet facilities to be located inside the home, for the convenience and security of the user, especially women and housebound people. The water used for flushing however now needs to be treated and if public sewers are not nearby, a septic tank provides a simple but effective method of removing the worst of the contaminants.

Contents

Introduction.....	1
How a septic tank works.....	1
Why use a septic tank?.....	2
Aqua privies.....	3
Location.....	4
Treatment processes.....	5
Design.....	6
Operation.....	17



This guide is about disposing of human wastes and sullage using septic tanks and aqua privies. It describes how they work and discusses how they are designed and constructed.

© WEDC, Loughborough University, 2011

Author: **Bob Reed** Edited by Louise Medland and Brian Reed

Illustrations: Rod Shaw

Quality assurance: **Mike Smith**

Designed and produced by WEDC Publications

This guide is one of a series of published learning resources which are available for purchase in print or available to download free of charge from the WEDC Knowledge Base. Any part of this publication, including the illustrations (except items taken from other publications where WEDC does not hold copyright) may be copied, reproduced or adapted to meet local needs, without permission from the author/s or publisher, provided the parts reproduced are distributed free, or at cost and not for commercial ends and the source is fully acknowledged. Please send copies of any materials in which text or illustrations have been used to WEDC at the address given below.

Published by WEDC, Loughborough University
Funded by Water & Sanitation for the Urban Poor (WSUP)

ISBN 978 1 84380 169 6

**Water, Engineering and Development Centre
School of Civil and Building Engineering
Loughborough University
Leicestershire LE11 3TU UK**

T: +44 (0) 1509 222885 LinkedIn: [WEDC UK](https://www.linkedin.com/company/wedc-uk)

E: wedc@lboro.ac.uk Twitter: [wedcuk](https://twitter.com/wedcuk)

W: wedc.lboro.ac.uk YouTube: [wedclboro](https://www.youtube.com/wedclboro)



Introduction

In situations where high volumes of sullage as well as water and waste from toilets are likely, a septic tank may be a practical long-term sanitation solution. Wastes from toilets, and sometimes also kitchen and bathrooms, are flushed into the septic tank through connecting pipes. The tank is buried in the ground to collect the waste, where the solids then settle and the remaining liquid effluent passes on to a secondary disposal system such as a soak pit or drainage trenches.

An aqua-privy is like a single-chamber septic tank, except the toilet is located directly over the tank. The volume of water required for flushing is reduced, as it is not needed to carry solids along connecting pipes.

How a septic tank works

A septic tank comprises a sealed tank with an inlet and outlet, usually constructed with two compartments, to improve the efficiency of settlement.

After one to three days of retention, partially-treated effluent flows to a sewer or soakage system.

During the retention period, solids settle out by gravity and undergo a process of decomposition in the tank. This results in the production of water, gases, sludge and a layer of floating scum. The settled solids gradually form sludge on the base of the tank, which must be removed periodically to retain space for more solids to settle.

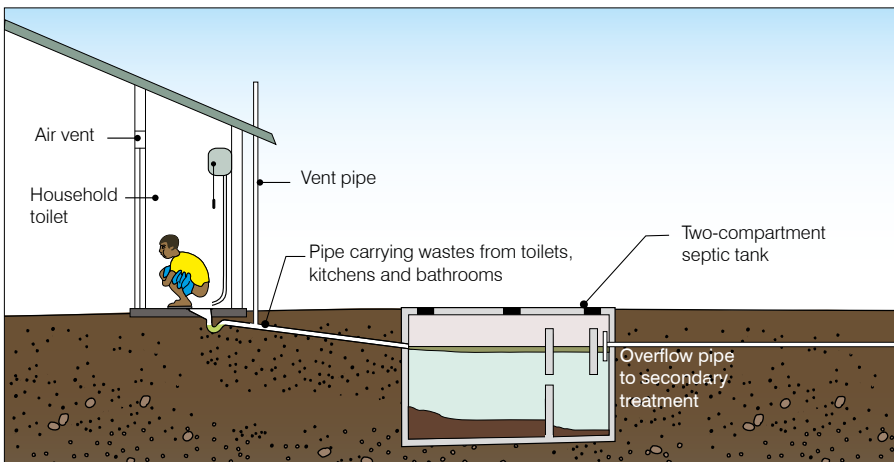

Figure 1. Wastewater treatment using a septic tank

Why use a septic tank?

Septic tanks are commonly used for the treatment of wastewater from individual households in low-density residential areas, institutions such as schools and hospitals, and from small housing estates.

The wastewater may be from toilets only (sewage), or include sullage (wastewater from kitchens, laundries and bathrooms, also called 'greywater'). Septic tanks may be appropriate for situations where the volume of wastewater produced is too large for disposal in pit latrines and water-borne sewerage is uneconomic or unaffordable.

Advantages

If correctly installed and maintained, a septic tank and drainage system is a reliable and odour-free system for

removing large quantities of sewage and sullage that may otherwise be left to drain on the ground surface.

The toilet can be located in the house, which many users may prefer as it is convenient, secure and private. This is especially important at night or in bad weather. Women and housebound people in particular can benefit.

Disadvantages

The system is a relatively high form of technology and expensive when compared with other on-plot sanitation options. It needs a reliable water supply (which will need to be paid for), care with operation and maintenance, as blockages can occur, and regular emptying. It is more complex where sub-surface disposal is not possible due to impermeable soils or a high water table.

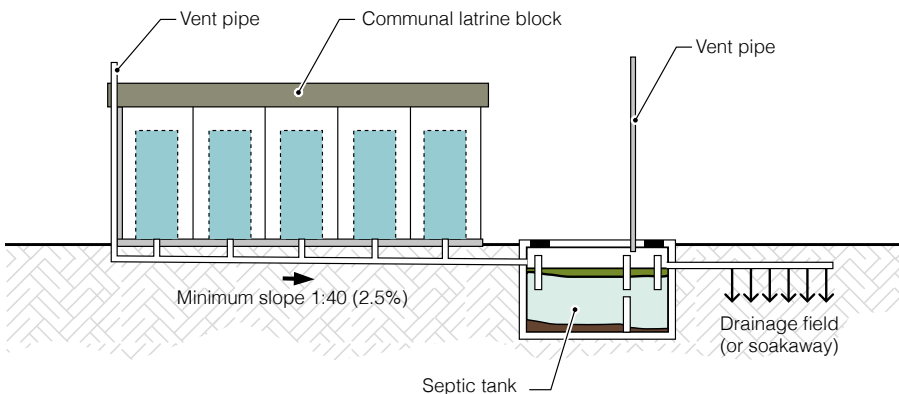

Figure 2. Communal toilet connected to a septic tank and drainage field

Groundwater pollution from septic tank drainage fields is more likely than from pit latrines because the volume of liquid infiltrated is much greater. Potential impacts on groundwater must be carefully considered.

Aqua privies

Although an aqua privy is very similar to a septic tank, the latrine is located directly over the tank, which means

less water is needed for flushing. It also reduces construction costs, as the area of land required is less too and sub-surface drainage for soaking away the effluent is reduced. As drop-pipes are used from the toilets directly into the pits, blockages are less likely and solid anal cleansing material may be used. An aqua-privy is therefore an ideal solution where pit latrines are considered unacceptable, but the volumes of sullage are small.

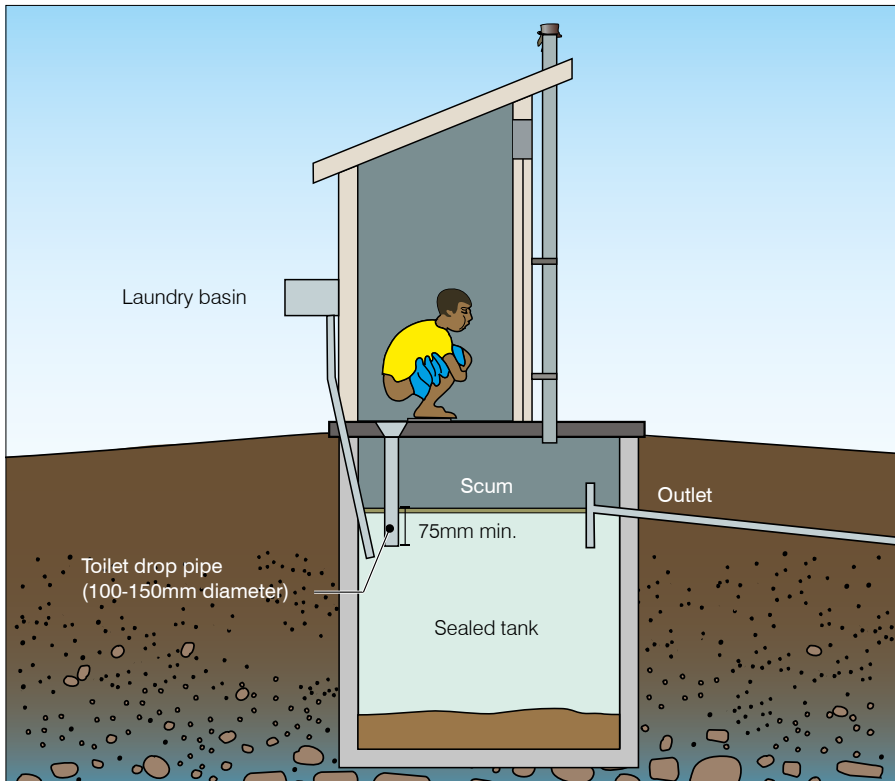

Figure 3. An aqua privy

Odours and flies from the tank may be excluded from the superstructure by fitting a water seal pan (for those who use water or soft toilet tissue for anal cleansing), or extending the drop pipe 75mm below the water surface (for those who use solid material for anal cleansing).

The tank of the aqua privy must be watertight to maintain a constant liquid level.

Advantages

As with septic tanks, these latrines are easy to clean, and it is more efficient to empty one big tank than individual pour-flush latrines. They are cheaper and less maintenance than septic tank systems.

Disadvantages

Again, like septic tanks, they are relatively expensive and difficult to construct, and need a reliable water supply. The latrine may not be as easy to construct inside a house.

Location

The tank must have an external access cover and vehicular access, as it will need to be emptied and blockages removed.

The tank should still be close to the toilet however, to reduce blockages between the toilet and the tank. If sullage from laundries, kitchens and bathing areas are also being disposed of, these activities should be upstream of the toilet, as the

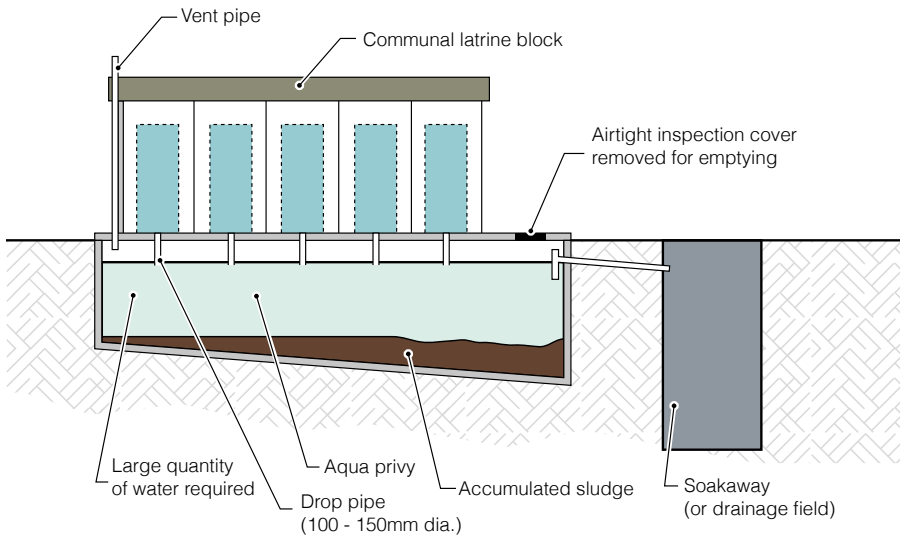

Figure 4. An aqua-privy for a communal latrine (e.g. a school)

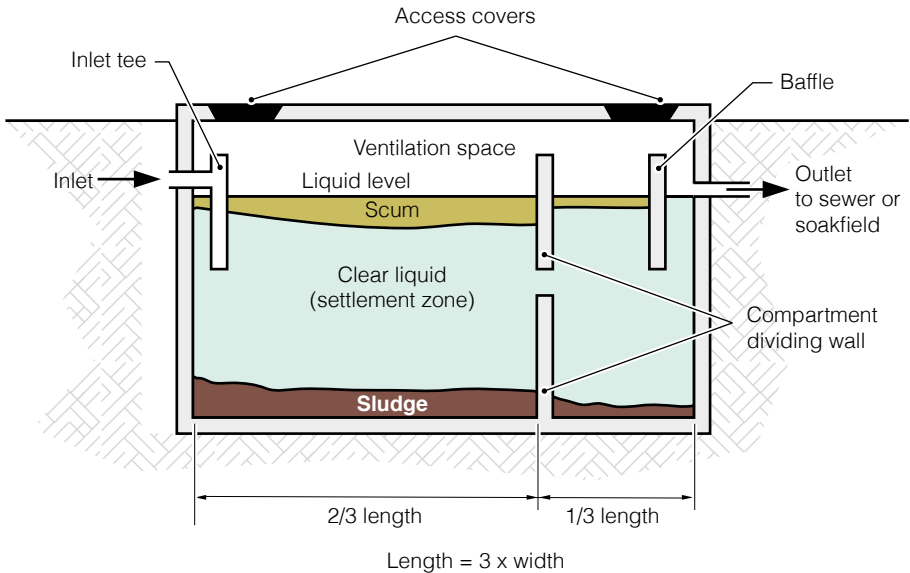

Figure 5. Treatment process in a septic tank

additional water will help keep the pipes clear of blockages.

The tank needs to be able to drain to a sewer or soakaway, so there needs to be an adequate slope. The site for the tank should not be waterlogged or prone to flooding. Surface water drains must not be connected to the septic tank, as this will flush partially treated sewage out during storms.

Treatment processes

Wastes from toilets, and sometimes kitchens and bathrooms, pass through pipes to a watertight tank where they are partially treated. This is the primary stage. Septic tanks and aqua privies do not provide complete treatment for wastewater.

A secondary treatment process must always follow them before the effluent is discharged into the open environment. In most cases this will take the form of sub-soil infiltration. The wastewater is allowed to soak into the soil where the liquid is disposed of and naturally cleaned at the same time. While the wastes are in the tank a number of treatment processes take place.

Settlement

The shape and size of the septic tank is designed to provide calm conditions in the liquid. This allows the heavy solids to settle to the bottom. Dividing the tank into a number of compartments improves the efficiency of the solids removal.

Anaerobic digestion

Organisms use oxygen to metabolise organic matter. Aerobic organisms use oxygen in the air or oxygen dissolved in water. If there is no oxygen, the environment is called anaerobic and organisms have to use other sources of oxygen, a process called reduction. Thus:

Anaerobic bacteria + organic waste
 \rightarrow new bacteria + CO_2 + CH_4 + H_2S

H_2S (hydrogen sulphide) has a characteristic 'rotten egg' smell.

Aerobic organisms are generally more efficient at breaking down organic material than anaerobic. A few organisms can live in both environments but most are adapted to survive in one or the other.

The settled solids form a *sludge* on the bottom of the tank, which gradually increases in thickness and must occasionally be removed.

Flotation

Some of the solids in the incoming liquid are lighter than water and float to the surface to form a *scum*. This includes materials such as grease and oil. The decomposition process which takes place in the settled sludge produces gas which mixes with the sludge to form a substance that is lighter than water. This

rises to the surface of the tank to join the scum. Over time, the scum layer thickens and the surface may harden.

Sludge digestion and consolidation

The rate at which sludge builds up in the tank is slower than the rate at which it is deposited. Two processes contribute to this:

- The sludge at the bottom of the tank is compressed by the weight of new material settling on top, increasing its density.
- Organic matter in the sludge and scum layers is broken down by bacteria which convert it to liquid and gas. The process is called sludge digestion. The rate at which the sludge digests depends on the liquid temperature, being greatest at 35°C .

Stabilisation

The liquid in the tank undergoes some natural purification but the process is not complete. The final liquid (effluent) is anaerobic and may still contain pathogenic organisms.

Design

The design of a septic tank aims to:

- produce a tank in which wastewater is contained for long enough for the maximum removal of suspended solids;
- prevent suspended solids from being discharged with the effluent;

- provide sufficient space for the sludge and scum to accumulate between desludging;
- ensure that no blockages are likely to occur; and
- provide adequate ventilation for gases.

Tank volume

There are many different formulae in use for calculating the size of a septic tank. They produce widely differing results. The reason for the difference is not completely clear but it can be partly attributed to the broad range of environments in which septic tanks are expected to work. For example, will a septic tank in the United Kingdom, where the climate is cool and water consumption high, function in the same way as one in Bangladesh where the temperature is much hotter and water

Influent and effluent

These terms simply refer to liquids that flow in (influent) or flow out (effluent). The terms can be applied to an overall sequence of treatment stages, with untreated wastewater being the influent, and treated wastewater being the effluent. The terms can also be applied to individual treatment stages, with liquids entering the treatment stage being the influent, and those leaving being the effluent from that stage.

consumption per capita is generally lower? There are also variations in desludging frequencies. This may also be because many of the formulae in use were developed many years ago and there is little reliable evidence to support their accuracy.

The method presented here was developed at WEDC some years ago by synthesising the results produced by other formulae then being used.

There are three divided spaces within a septic tank:

- A. Space for the retention of the volume of clear liquid (settlement zone).
- B. Storage space for sludge and scum.
- C. Ventilation space.

Each is designed separately and the results combined to give the total volume.

A: Clear liquid retention volume

The volume required for storing the liquid wastewater can be calculated using the formula:

$$A = Q \times T/24$$

Where:

A = the retention volume (m³)

Q = the volume of wastewater to be treated per day (m³)

T = the average time wastewater is retained in the tank (hrs)

Wastewater volume

The volume of wastewater to be treated each day is generally based on water consumption. It is very rare to measure wastewater flow rates from small sources. Not all of the water used will end up as waste. Some will be lost by discharge of wastewater outside the property, some by disposal in other ways (e.g. on a garden) and some through evaporation.

Water consumption rates in households that have to carry their water from elsewhere are normally less than twenty litres per person per day. Most of this will be used for drinking or for washing and very little polluted wastewater is produced. Where water is supplied to the house, consumption will go up markedly. It is common to assume that where all liquid wastes are treated in a septic tank the daily inflow will be between 70 to 90% of the daily water use.

The situation is different in communities that have very high water consumption. High water use usually indicates that much of the water supply is being used for activities such as filling swimming pools, washing cars or watering the garden. It is therefore common to assume that the maximum wastewater flow from domestic properties is 200 litres per person per day rather than a fixed proportion of consumption.

Households are not static, so some allowance needs to be made for water use to increase.

What is wastewater?

Wastewater can consist of:

- Sullage (grey water)
- Flushing water (sewage or black water)
- Some surface water

About 99.9% of the material in sewage is water; in domestic areas this typically represents about 75 to 80% of potable water supplied. Sewage may contain coliform bacteria; pathogens; aerobic, anaerobic and facultative bacteria; and organic and inorganic matter. The characteristics of wastewaters depend on their quantity and composition.

Surface water does not need to be treated in a septic tank, so this should not be connected to a drainage system.

Hydraulic retention time T

The amount of time sewage spends on average in a tank is known as the hydraulic retention time. This can be between one and three days.

Hydraulic retention time (hr) =

$$\frac{\text{volume of tank (m}^3\text{)}}{\text{flow rate (m}^3\text{/hr)}}$$

Calculations for wastewater flow for commercial and institutional buildings must be based on detailed investigations of their water use.

Tank retention time

Disturbance of the liquid in a septic tank is mainly caused by the inflow of fresh wastewater. The turbulence will affect a greater proportion of a small tank than a large one. It is necessary therefore to retain the liquid longer in small tanks to overcome this disturbance.

B: Sludge and scum volume

The volume required for sludge and scum can be estimated using the formula:

$$B = P \times N \times F \times S_d$$

where:

B = the required sludge and scum volume (m³)

N = the number of years between desludging (commonly 2- 5 years)

P = the number of people served (which may change)

F = the factor for sludge digestion rate (to compensate for the variation in sludge digestion rate caused by tank liquid temperature).

S_d = the annual rate of sludge and scum production (m³/person/yr.)

Sludge and scum production rates

The value of S_d is based on commonly accepted figures for annual accumulation rates for a septic tank in constant use (S_a), which are: 0.025m³/person/year for WC wastes only; and 0.040 m³/person/year for WC wastes and sullage.

It is reasonable to reduce sludge accumulation rates if the septic tank is not in full time use or other special reasons, using multiplying factors (V) to adjust sludge accumulation rates (S_a) for various non-standard applications. If more than one multiplying factor is relevant to the situation, multiply the factors.

Therefore, the design sludge accumulation rate would be:

$$(S_d) = S_a \times V_1 \times V_2 \times \text{etc.}$$

Table 1. Recommended retention times

Daily wastewater flow (Q)	Hydraulic retention time T' (hours)
Less than 6 m ³	24
Between 6 and 14 m ³	33 - 1.5 Q
Greater than 14 m ³	12

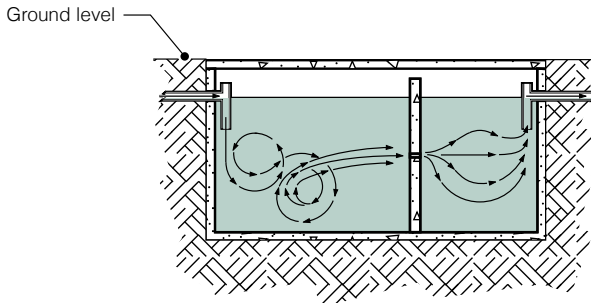

Small tank – turbulence takes up a large proportion of the first tank

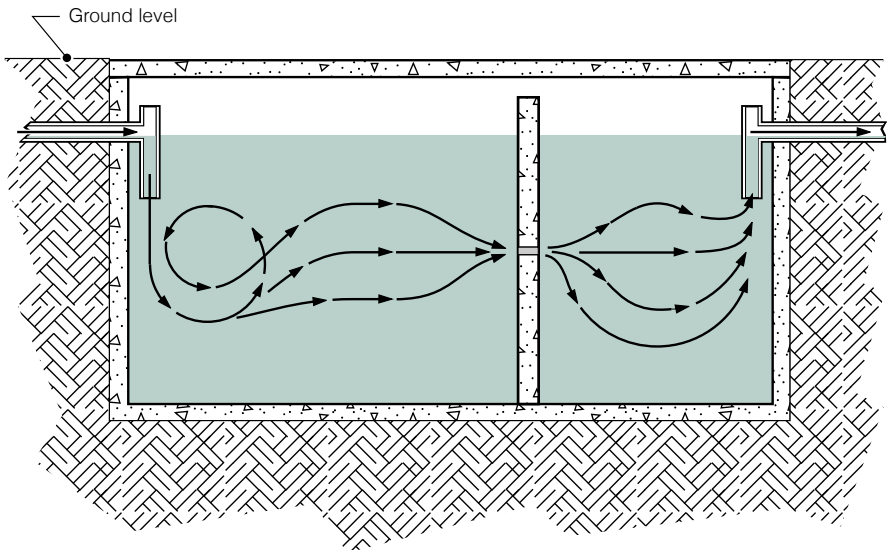

Large tank – turbulence takes up a much smaller proportion of the first tank

Figure 6. A comparison of the effects of turbulence on small and large tanks

Actual sludge accumulation rates

It is better to measure the actual accumulation rate locally if possible. If measured figures are used, they should replace $F \times S_d$ in the formula as it is not possible to separate the effects of sludge consolidation from digestion. As a general rule it can be assumed that two thirds of the volume is sludge and one third scum.

Table 2. Values for the sludge digestion factor 'F'

Years between desludging	Average air temperature		
	Greater than 20°C all year	Between 10 and 20°C all year	Less than 10°C in winter
1	1.3	1.5	2.5
2	1.0	1.15	1.5
3	1.0	1.0	1.27
4	1.0	1.0	1.15
5	1.0	1.0	1.06
6 or more	1.0	1.0	1.0

C: Ventilation space

A 300mm minimum air space should be left between the top of the liquid level and the bottom of the cover. This is to accommodate the rise in the level of the top of the scum above the liquid level as the scum floats on the liquid and allow space for gases to escape through the ventilation system.

D: Total tank volume

The total volume of a tank (D) is given by the formula:

$$D = A + B + C$$

However A + B should never be less than 1.3m³, as it is not possible to produce

calm conditions in a septic tank smaller than this.

Dimensions

Rectangular tanks should be divided into two compartments. This reduces turbulence in the tank (keeps the liquid calm) and helps to spread the flow evenly throughout the tank.

The best results are obtained when the first compartment is twice the size of the second.

In the past, some tanks have been divided into three or more compartments. There is no evidence to show that this improves the quality of the final effluent.

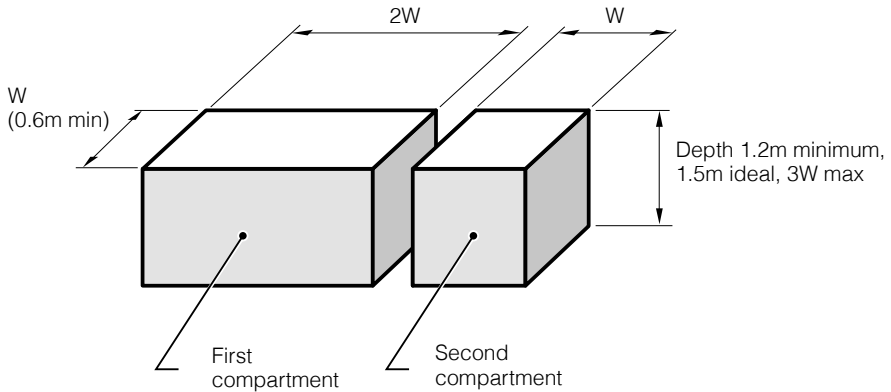

Figure 7. Tank dimensions for liquid, scum and sludge volume

The following guidelines can be used for calculating the internal dimensions of the tank.

- The depth of liquid from the tank floor to the bottom of the outlet pipe should be at least 1.2m and preferably 1.5m or more.
- The width of the tank (W) should be at least 0.6m . This is the minimum width in which a person can work when constructing the tank or desludging.
- The width of the tank should be half the length of the first compartment and the width of the second compartment should be equal to its length.

The depth of the liquid should be greater than the width of the tank but less than the tank's total length.

In larger tanks the base often slopes towards the inlet end of the tank. This is because most of the sludge collects under the inlet. Providing extra volume in that area increases the efficiency of the unit. Use the average depth of the tank for design purposes.

Tank components

Except for small domestic units, the structural components of septic tanks should be designed professionally. The floor, cover and possibly the walls may need to be reinforced, requiring the skills of a structural engineer.

Base

In small tanks, the base is usually made of unreinforced concrete about 100 to 150mm thick. This is thick enough to withstand the uplift pressure when the tank is empty and act as a foundation for the walls.

Table 3. Suggested multiplying factors V for septic tanks in part-time use

Situation	Factor (V)
Tank used only part of the year	Number of days in use ÷ 365
Buildings open normal office hours (inc. schools)	0.5
Wastes from secondary/ high school children	0.75
Wastes from primary school children	0.5
Wastes from nursery school children	0.25

In larger tanks the floor will have to be reinforced to carry the imposed loads and prevent cracking.

Walls

Walls are made of bricks, blocks, stone or concrete. It is conventional to make the walls watertight, but in most cases the effluent is going to be disposed of underground so there should be no problem with allowing some of it to escape through the walls of the tank. Check that there is no potential for pollution of nearby water sources or the water table is not so high as to cause groundwater to flow into the tank rather than effluent out. If there is a potential for groundwater pollution and the tank effluent is being discharged to a sewer for disposal elsewhere then the tank should be made watertight.

The space between the walls and the sides of the excavation should be filled with a granular material such as fine gravel.

Cover

The tank cover is usually made of concrete. Access holes with covers should be provided over the inlet, outlet and dividing walls to allow for desludging and maintenance. In large tanks the cover may be made of a series of removable slabs that are light enough so that each can be removed manually.

Inlet and outlet

The construction of the inlet and outlet is critical to the performance of the tank. The wastewater must enter and leave the tank with the minimum of disturbance (to optimise settlement of the solids) and be easy to maintain. For smaller units (serving one or two families) a 'tee' piece design is the most appropriate.

In larger units the outlet tee piece should be replaced by a weir and scum board plate. The scum board is to prevent the floating solids from being washed into the outlet pipe. Do not use a weir on the inlet, as it will become fouled with large solids.

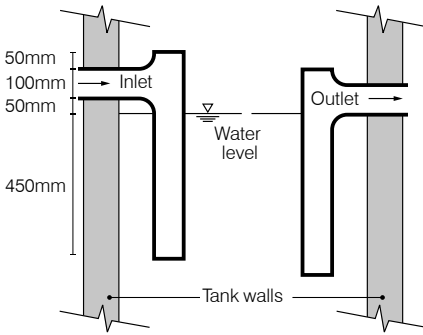

Figure 8. Tank inlet and outlet pipes

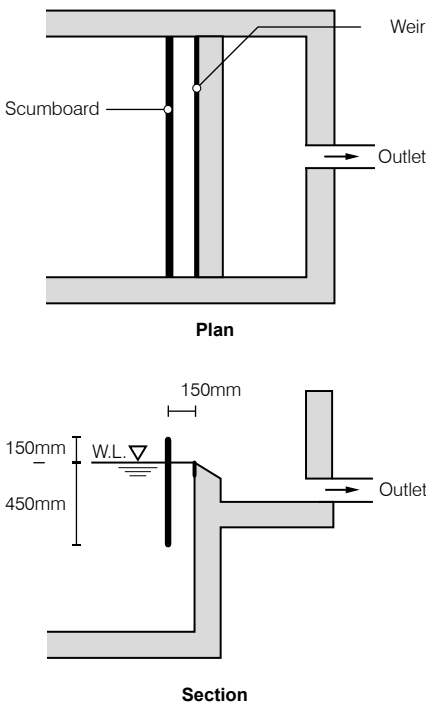

Figure 9. Tank outlet using overflow weir

Dividing wall

The dividing wall must have a facility for allowing the effluent to pass from one compartment to another. This can be achieved either by installing tee pieces through the wall at water level or leaving holes (slots) in the wall. In either case, the openings should be designed to minimise turbulence by ensuring the average velocity through them does not exceed 0.1m/s. The openings must be in the middle of the settlement zone, not in the sludge or scum zones.

Ventilation

The decomposition of the organic wastes produces gases and a route must be provided for their escape. The simplest option is to allow the gases to escape along the inlet wastewater pipe. This can only be used if the pipe system is fitted with a ventilation pipe at its highest point. The other option is to fit a screened ventilation pipe in the roof of the tank. The gases given off by septic tanks have a strong smell so they should be vented above normal head height.

Tanks for aqua privies

Tanks for aqua privies are the same as septic tanks with the toilet situated directly above the tank. The small volume of water used means that there is minimal turbulence and so there is no need for two compartments and the minimum allowable volume can be reduced to 1.0m³. The tank shape is less critical than for a septic tank.

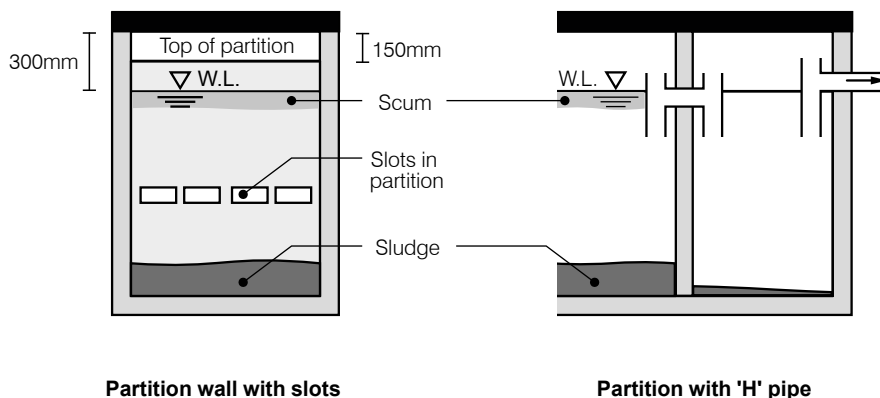

Figure 10. Options for flow through tank partitions

It can be square, rectangular or circular. Aqua privies are quite a good way of upgrading pit latrines where water consumption has increased and the pit walls can no longer absorb all the effluent.

The tank of an aqua privy must be watertight because any leakage will cause the water level to drop. This will expose the bottom of the drop pipe and allow odours to enter the superstructure. Top-up water can be provided by fitting a laundry basin or shower cubicle on the side of the superstructure. The water from the basin can be piped into the tank. The waste pipe should extend at least 75mm below the water surface to provide an odour seal.

Secondary treatment

After one to three days the liquid wastes leave the tank and are carried to the secondary treatment system. This is

commonly some form of underground disposal system. Where the soil permeability and ground conditions are suitable, common disposal methods are by absorption into the ground using a soak pit or an infiltration trench. These distribute the effluent into the soil, where it becomes purified by filtration and biological processes.

A large area of land is normally required as septic tank effluent infiltrates very slowly. This limits the plot size and housing density for which septic tanks are a feasible option. Where the soil permeability is not sufficient for such soakage systems to work, above-ground systems, such as evapo-transpiration beds, can be constructed.

Alternatively they may be discharged to a sewerage system for secondary treatment elsewhere. A septic tank that

discharges into a sewer removes solids from the sewage and attenuates flows. This enables a smaller pipe to be used as the sewer and it can be laid at a shallow gradient as it does not have to flush significant amounts of solid material.

Most failures of septic tank and aqua privy systems are initially due to the failure of the effluent disposal system. This may be due to poor effluent disposal system design or poor design and operation of the tank.

Prefabricated tanks

Many companies manufacture prefabricated septic tanks. They are usually made of plastic or fibre glass and come in a variety of shapes and sizes. Good manufacturers will assist in the selection of the right tank size for the requirements; provide advice on installation and even design the final disposal system. Prefabricated tanks are normally inappropriate if they are to be desludged manually. They are also difficult to transport far.

Whilst the use of prefabricated tanks is on the increase many are still constructed from local materials in the position where they will be used. These are occasionally cylindrical in shape but more often they are rectangular.

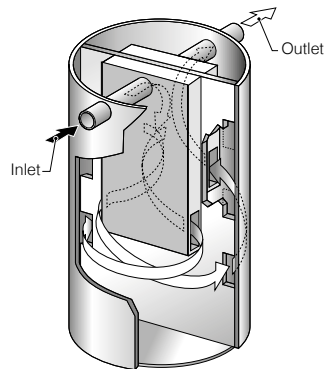
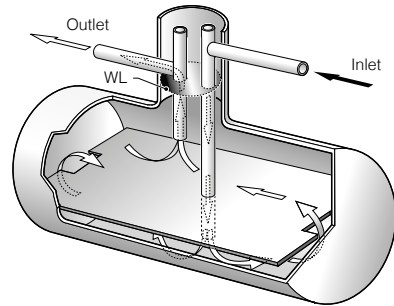
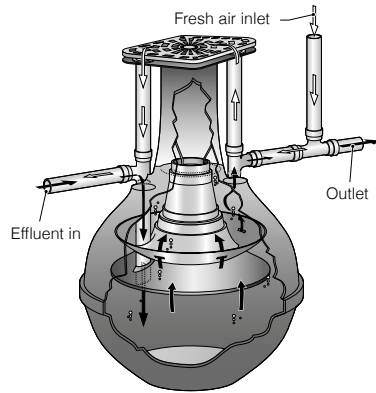

Figure 11. Examples of pre-fabricated septic tanks

Operation

Preventing problems

To avoid blockages and make emptying easier, only toilet paper and faeces should be flushed into a septic tank. Large amounts of chemicals (including bleach) should not be disposed of into the tank as this will kill the bacteria that are digesting the sludge.

Sludge removal

Sludge should be removed at regular intervals. This should be carried out from the surface as the tank itself will lack enough oxygen for people to breathe.

Even though a septic tank can be left for several years without desludging, a regular programme will prevent it from neglect. If the sludge is more than a third of the tank volume, then the tank needs emptying.

Some sludge should be left in the tank after removal to ensure the right bacteria are present to digest faeces.

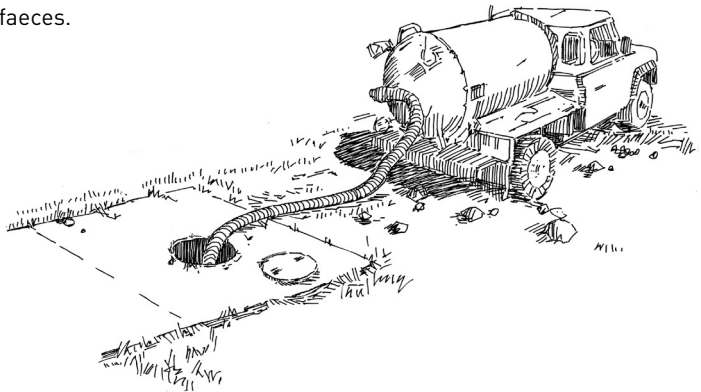

Figure 12. Sludge removal

The Water, Engineering and Development Centre is one of the world's leading education and research institutes for developing knowledge and capacity in water and sanitation for sustainable development and emergency relief.

WEDC is committed to the provision of effective, evidence-based and appropriate solutions for the improvement of basic infrastructure and essential services for people living in low- and middle-

income countries. With over 40 years of experience, WEDC offers expert advice and quality learning opportunities for sector professionals.

Founded in 1971, WEDC is based in the School of Civil and Building Engineering at Loughborough University, one of the top UK universities. Being a part of a leading university gives us a recognised platform of independence and quality. Visit our website to find out more about our wide range of activities.



WEDC, Loughborough University, Leicestershire, LE11 3TU, UK
t: + (0) 1509 222885 w: <http://wedc.lboro.ac.uk>

WSUP was established in 2005 and has become recognised as a leading actor in the urban WASH sector, demonstrating how multi-sector partnerships can have significant impact.

By harnessing the expertise and sector leading knowledge of the private sector, NGOs and research institutions, WSUP works as a professional partner to service providers in the delivery of water and sanitation programmes. WSUP's integrated programmes offer an unrivalled package of support, combining capacity building of all stakeholders and development of relationships between

service providers and low income communities to deliver sustainable, improved services.

Our approach emphasises planning to achieve sustainable change at scale. We do this by demonstrating financially viable approaches to serving low income areas, and using this as a basis for advocating for wider scale up of such approaches by service providers and local and national governments and their partners, the multilateral financing institutions.



UK Office: Capital Tower, 91 Waterloo Road, London, SE1 8RT, UK
t: +44 (0)20 3170 0935 w: <http://www.wsup.com/>